



ORO HD-46

46 CFM HYD COMPRESSOR



The **ORO HD-46** compressor is born out of the requirement for an extremely reliable compressor that will stand up to the most demanding mobile applications - guaranteed.

Originally designed for use in open-pit mines in the Canadian Arctic, these units will provide years of trouble-free service and continue to operate where other systems fail.

The HD-46 is built around the Champion® R-30D reciprocating compressor pump and high-quality hydraulic components, which combine to create the most reliable compressor, inside and out.

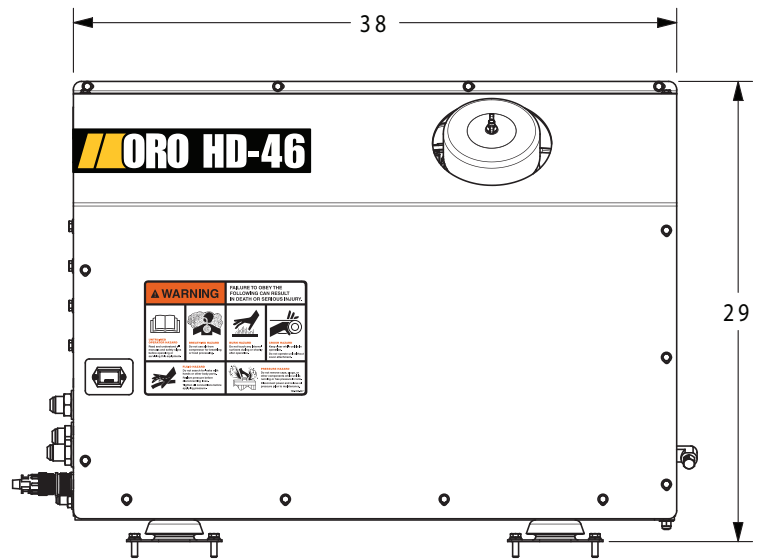
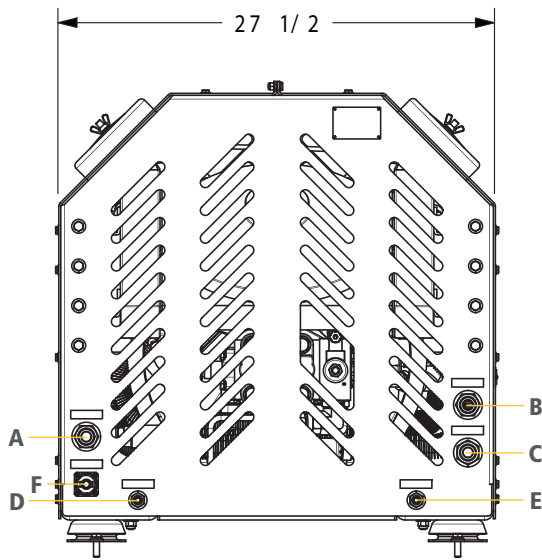

SPECIFICATIONS

AIR COMPRESSOR OUTPUT	46 CFM @ 175 PSI
HYDRAULIC FLOW REQUIRED	14 GPM @ 2850 PSI
ENGINE/SHAFT RPM	ENGINE RPM BETWEEN 1000 AND 1200 TO ACHIEVE MAXIMUM COMPRESSOR SHAFT SPEED OF 950-1050 RPM.
COOLER	INTEGRATED HYDRAULIC OIL COOLER WITH 12V FAN
HYDRAULIC PUMP	CHAMPION® R-30D, 15 HORSEPOWER
INTAKE FILTER	10 MICRON INDUSTRIAL GRADE INTAKE AIR FILTER
WEIGHT (DRY)	600 LBS.
DIMENSIONS (INCH)	38W X 29H X 27.5D
ELECTRICAL VOLTAGE	12V DC
AIR RECEIVER	MINIMUM 15 GALLON AIR TANK REQUIRED TO ENSURE PROPER OPERATION (35 GALLON RECOMMENDED)
HYD RESERVOIR CAPACITY	MINIMUM 28 GALLON HYDRAULIC RESERVOIR REQUIRED
SAFETY FEATURES	3,000 PSI HYDRAULIC PRESSURE RELIEF VALVE, INTERSTAGE PRESSURE RELIEF VALVE

CONNECTIONS

HYDRAULIC PRESSURE IN [A]	MALE JIC-12	MOTOR CASE DRAIN [D]	MALE JIC-06
OIL RETURN (TANK) [B]	MALE JIC-12	AIR SENSE LINE [E]	MALE JIC-06
AIR OUTLET [C]	MALE JIC-12	ELECTRICAL CONNECTION [F]	4 PIN PLUG W/ HARNESS

*Available direct from ORO Design or through your local Drive Products branch.

ORO DESIGN
& Manufacturing

3 Small Crescent
Oro-Medonte, ON L0L 1T0
(705) 327-1567

WWW.ORODESIGN.CA

DRIVE
PRODUCTS

HEAD OFFICE | 1665 Shawson Drive
Mississauga, ON L4W 1T7
1 (800) 668-6012

WWW.DRIVEPRODUCTS.COM